

WSK031

数控蓝宝石多工位单线开方机

WSK031 CNC Sapphire Multi Station Monoline Squarer



机床用途与性能特征

- 本设备为金刚线单线切割机，主要用于LED蓝宝石晶体的切割，是新能源的主要配套设备；
- 采用国外进口数控控制系统，人机友好界面，操作简便；
- 设备布局合理，机械强度高而且热稳定性好；整体外观采用全封闭不锈钢设计；
- 摇摆单元优化了金刚线切割蓝宝石的性能，缩短了切割时间，并提高了晶锭的端面质量；减少滑轮数量的设计，更有效地降低线耗、滑轮等耗材；
- 设备采用三工位，可同时切割不同的蓝宝石晶体，也能独立控制每个工位，切割速度也可不同；
- 采用一套收放线同时带动3个工位，省线50%，同时也能使用多线切的旧线来切；
- 优化张力控制系统，利用高张力切割，保证了切割的质量和效率；
- 采用三工位旋转工作台，多方位调节晶向，单一平面布线等方案；
- 采用整体式设计，配备切割用水箱，外观美观且内部整洁。

Main Applications and Structural Features

- This equipment is diamond monoline squarer, applied in processing LED sapphire ingots, which is the main equipment for new energy industry.
- Apply abroad imported CNC control system, friendly human-computer interface, easy to operate.
- Reasonable layout, high mechanical strength and perfect thermal stability. Overall appearance applies full-closed stainless steel design.
- Swing unit optimizes performance of slicing sapphire, shortening time, and improving end-face quality of ingots, reducing quantity of pulleys, which decreases consumables such as wire and pulleys.
- Apply tree-station, slicing different sapphire ingots simultaneously, or control each station separately, speed of slicing can also be different.
- Apply one set of retractable cable that drives 3 stations, save 50% wire, and be able to use old wire used in multi-line as well.
- Optimize tension of control system, by high-tension slicing, ensuring quality and efficiency of squaring.
- Apply tree-station rotary worktable, adjust crystal orientation on multi-aspect. Single plane wiring program.
- Apply overall design, matched with water tank for slicing, identical appearance and clean inside.

技术规格参数 Specifications and Technical Parameters

加工工件参数 Workpiece parameters	
工件规格 Specifications	Φ500x500mmx3件
工件重量 Weight	< 250Kgx3件
主要参数 Main parameters	
金刚线直径 Diameter of diamond wire	Φ0.23~0.5mm
工位数量 NO. of station	根据导轮槽距而定
工件台速 Speed of worktable	
加速度 Acceleration	(max)
线速度 Line speed	20m/s(max)
摇摆角度 Swing angle	±8°
摇摆速度 Swing	25度/秒
工件晶向 Workpiece crystal orientation	360° + 90°
切割方向 Slicing orientation	前进或后退切割/双向互换切割 forward or backwards slice/two-way exchange of cutting
电源供给及配套设施 Power supply and matched facility	
电源要求 Requirement of power	电压 voltage: 380V; 频率 frequency: 50Hz
冷却水流入温度 Cooling water	10°C-20°C
周围环境温度 Environment temperature	15°C-25°C

设备局部图 local picture

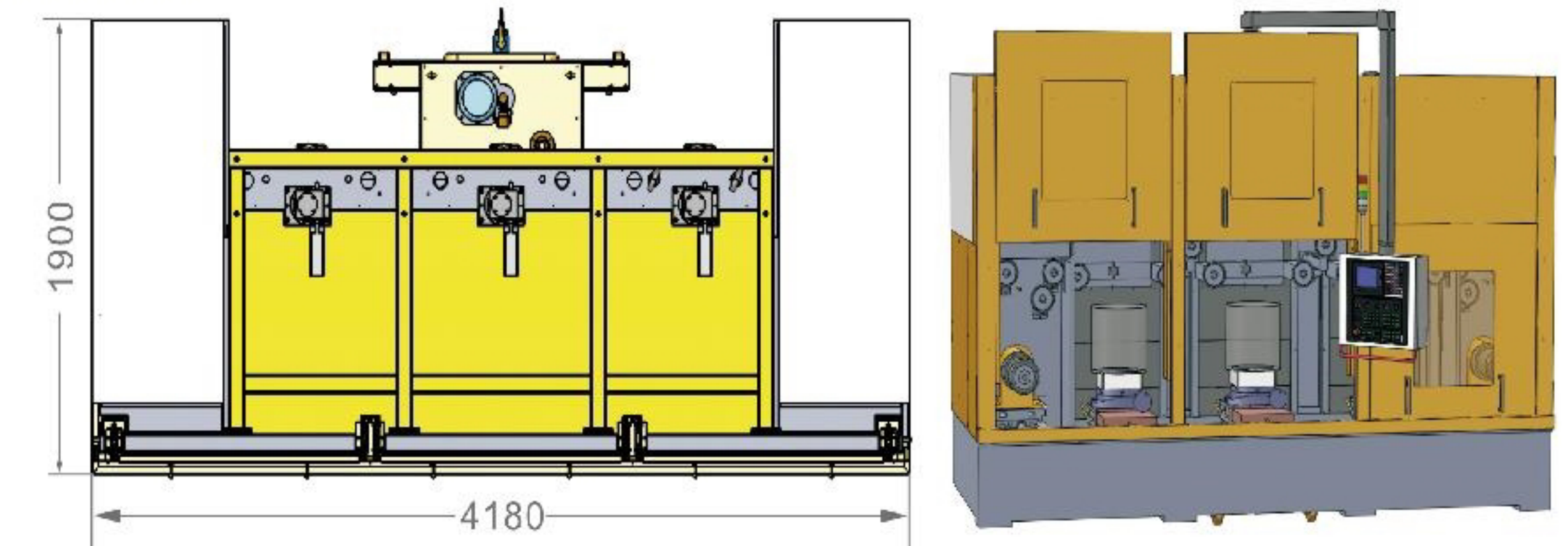

视窗加工流程图 windows processing flow chart

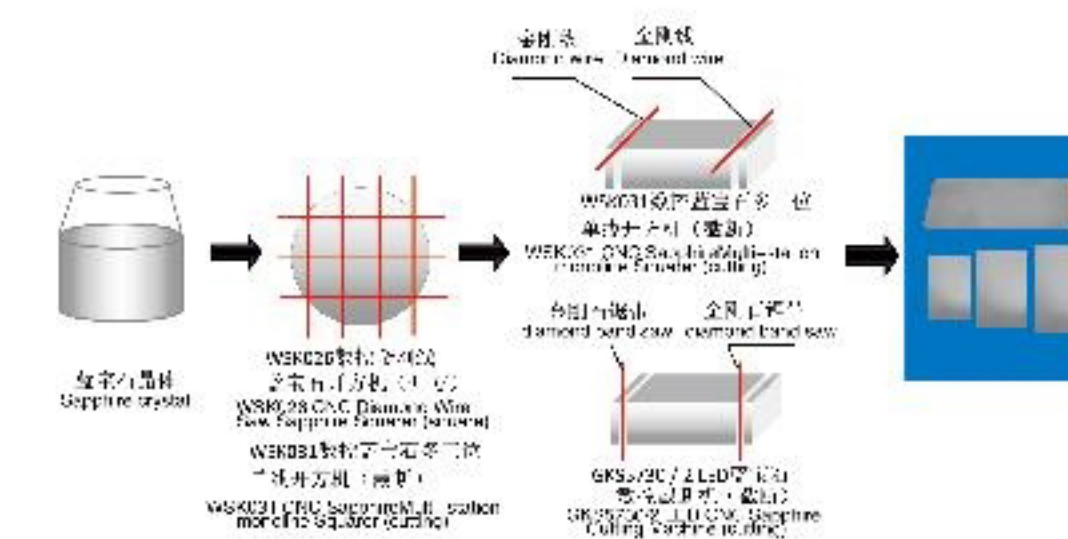

衬底加工流程图 Substrate Processing Flow Chart

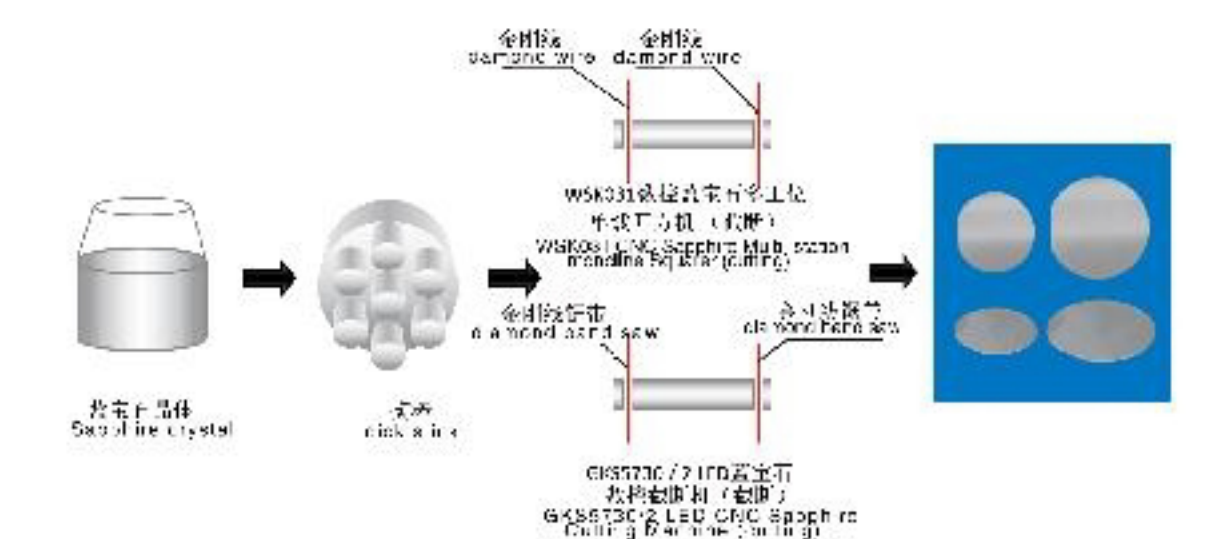

由于产品不断创新，本资料仅供参考，如有修改恕不通知，本公司保留最终解释权。
As products are improving gradually, the above information is only for reference, if any modification without notification, we company reserves the final explanation rights.